

Technical data	operation when directly connected to chimney
Energy label	A+
Operating data	
Nominal heat power / Power absorbed to water	13 / 7,9 kW
Efficiency	> 80 %
Consumption of wood	3,5 kg/h
Mass flow of flue gas	10,6 g/s
Required chimney pressure	12 Pa
Required amount of combustion air	30 m ³ /h
Average flue gas temperature	
on the output	211 °C
Heat distribution	
fireplace insert	13 %
door glass (single / double)	38 / 26 %
water	49–61 %
Water exchanger specifications	
Maximum working pressure	2,5 bar
Minimum return water temperature	60 °C
Water capacity	47 liters
Connection input / output	1" / 1"
Information for builds	
Minimal grill area supply / outgoing (with vent. grill)	200 / 250 cm ²
Minimum radiant area ³ (without vent. grill)	suitable
Minimum distance from insulated areas / floor	40 / 0 mm
Reference insulation ¹ ceiling / back wall / side wall / floor	100 / 60 / 60 / 0 mm
Calciumsilicate insulation ² ceiling / back wall / side wall / floor	75 / 45 / 45 / 0 mm
General technical information	
Total weight / lining weight	circa 294 / 87 kg
Burning chamber dimensions (width x depth)	535 x 315 mm
Combustion air connection	Ø 125 mm
Use in non-ventilated accumulation builds according to craft rules	suitable ⁴
Tested according to	EN 13229
Meets values	1. BlmSchV (Stufe2), 15a BVG

Nr.	Thread size	Description
1	G 1" (AG)	Water supply from heating system - min. 60 °C
2	G 1" (AG)	Hot water supply to heating system
3	G 1/2" (AG)	Water supply from the waterlines into the cooling loop
4	G 1/2" (AG)	Discharge of water from the cooling loop into the waste
5	G 3/8" (IG)	Pocket for air vent valve
6	G 1/2" (IG)	Pocket for thermal sensors
7	G 1/2" (IG)	Pocket for emptying

- 1 Mineral wool according to AGI-Q 132
- 2 Example SkamoEnclosure Board 225 kg/m³
- 3 Depends on accumulation period and material characteristics. Listed values calculated with average specific heat output = approx. 500 W/m²
- 4 With regard to the inspection capability and maximum ambient temperatures of the external switching devices (e.g. TAS/SV)

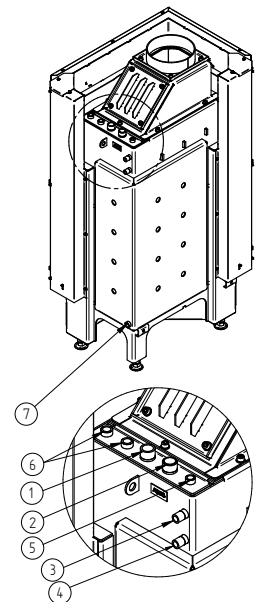

ECKA 67/45/51WL

Technical data
Version 09/2023

ECKA 67/45/51WL left side opening

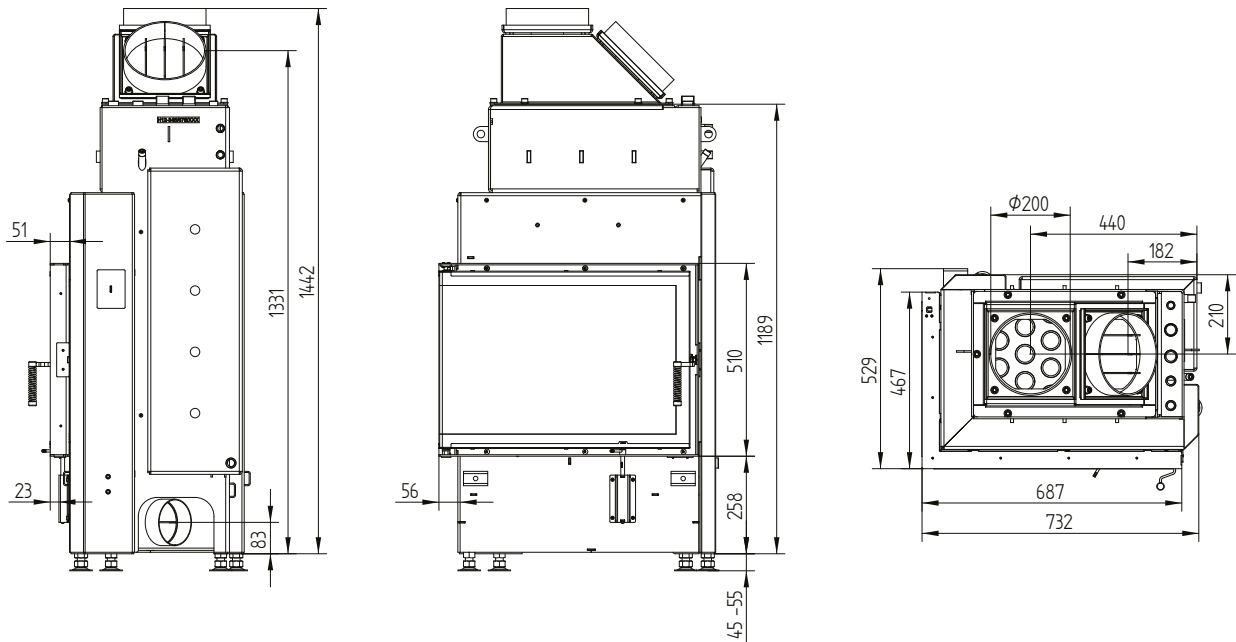

ECKA 67/45/51WL

Technical data
Version 09/2023

Cover frame 67/45/51 left-right side opening 6sides 1 x 90° 60 mm / air inlet

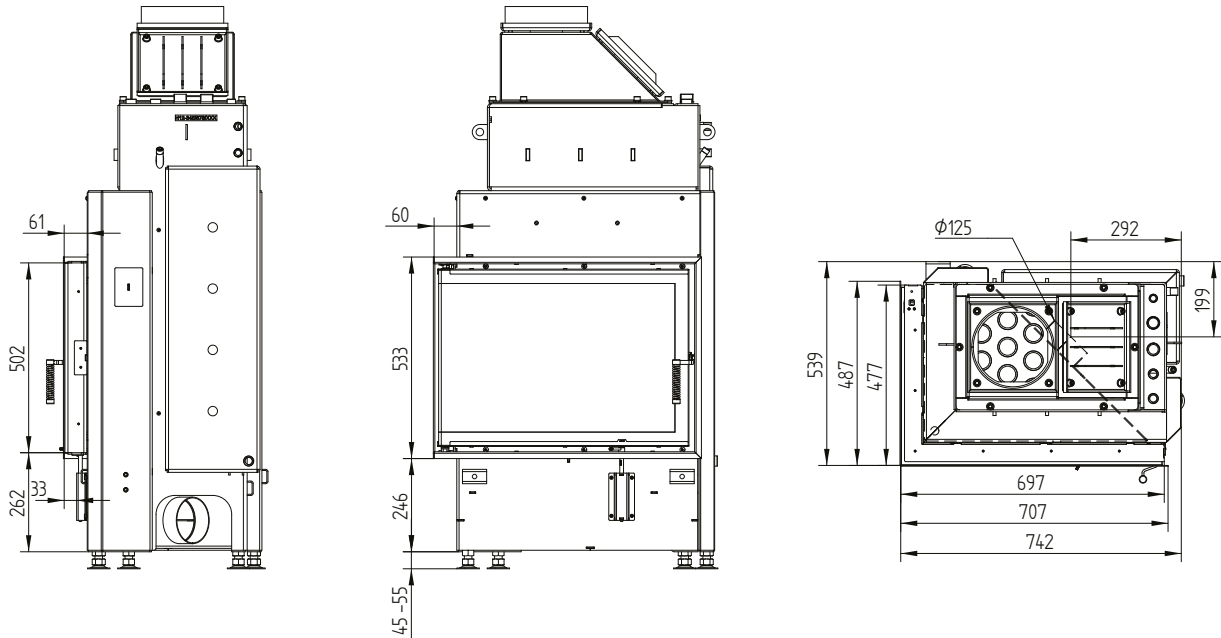

Build-on frame 67/45/51L left side opening 6sides 80 mm / feet

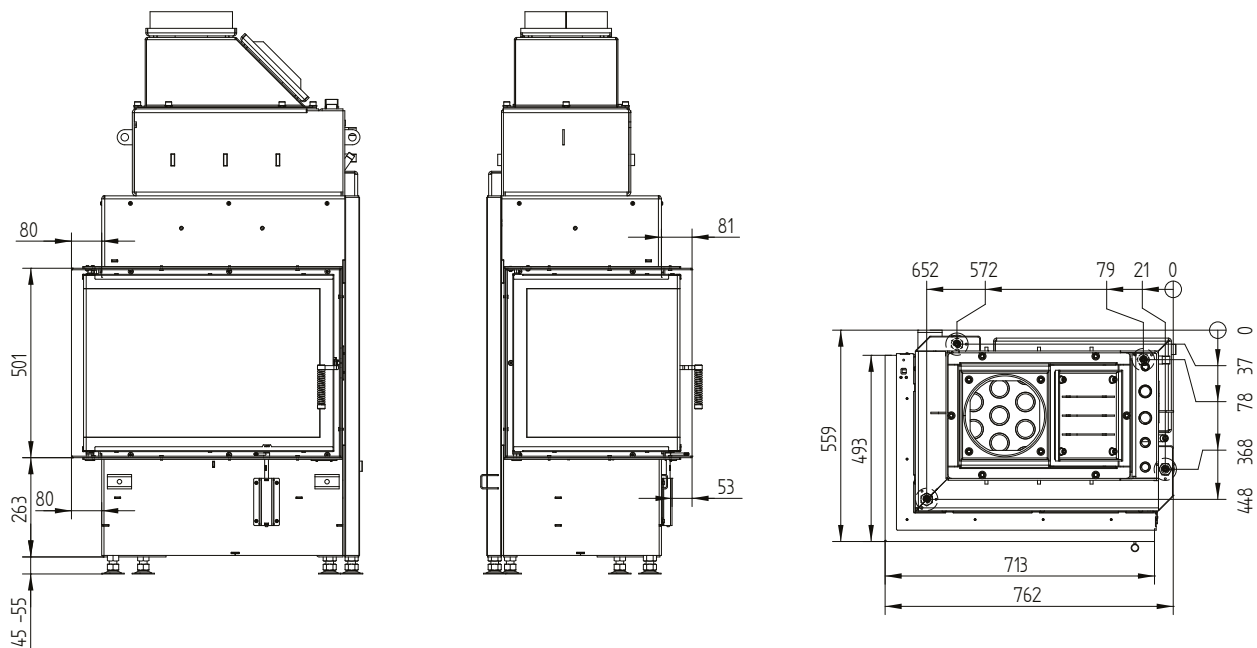

Technical data

Technical data	operation when directly connected to chimney
Energy label	A+
Operating data	
Nominal heat power / Power absorbed to water	13 / 7,9 kW
Efficiency	> 80 %
Consumption of wood	3,5 kg/h
Mass flow of flue gas	10,6 g/s
Required chimney pressure	12 Pa
Required amount of combustion air	30 m ³ /h
Average flue gas temperature	
on the output	211 °C
Heat distribution	
fireplace insert	13 %
door glass (single / double)	38 / 26 %
water	49–61 %
Water exchanger specifications	
Maximum working pressure	2,5 bar
Minimum return water temperature	60 °C
Water capacity	47 liters
Connection input / output	1" / 1"
Information for builds	
Minimal grill area supply / outgoing (with vent. grill)	200 / 250 cm ²
Minimum radiant area ³ (without vent. grill)	suitable
Minimum distance from insulated areas / floor	40 / 0 mm
Reference insulation ¹ ceiling / back wall / side wall / floor	100 / 60 / 60 / 0 mm
Calciumsilicate insulation ² ceiling / back wall / side wall / floor	75 / 45 / 45 / 0 mm
General technical information	
Total weight / lining weight	circa 294 / 87 kg
Burning chamber dimensions (width x depth)	535 x 315 mm
Combustion air connection	Ø 125 mm
Use in non-ventilated accumulation builds according to craft rules	suitable ⁴
Tested according to	EN 13229
Meets values	1. BlmSchV (Stufe2), 15a BVG

Nr.	Thread size	Description
1	G 1" (AG)	Water supply from heating system - min. 60 °C
2	G 1" (AG)	Hot water supply to heating system
3	G 1/2" (AG)	Water supply from the waterlines into the cooling loop
4	G 1/2" (AG)	Discharge of water from the cooling loop into the waste
5	G 3/8" (IG)	Pocket for air vent valve
6	G 1/2" (IG)	Pocket for thermal sensors
7	G 1/2" (IG)	Pocket for emptying

- 1 Mineral wool according to AGI-Q 132
- 2 Example SkamoEnclosure Board 225 kg/m³
- 3 Depends on accumulation period and material characteristics. Listed values calculated with average specific heat output = approx. 500 W/m²
- 4 With regard to the inspection capability and maximum ambient temperatures of the external switching devices (e.g. TAS/SV)

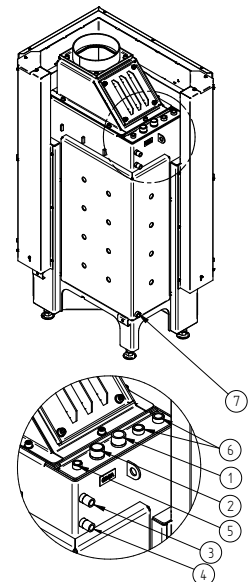

ECKA 67/45/51WR

Technical data
Version 09/2023

ECKA 67/45/51WR right side opening

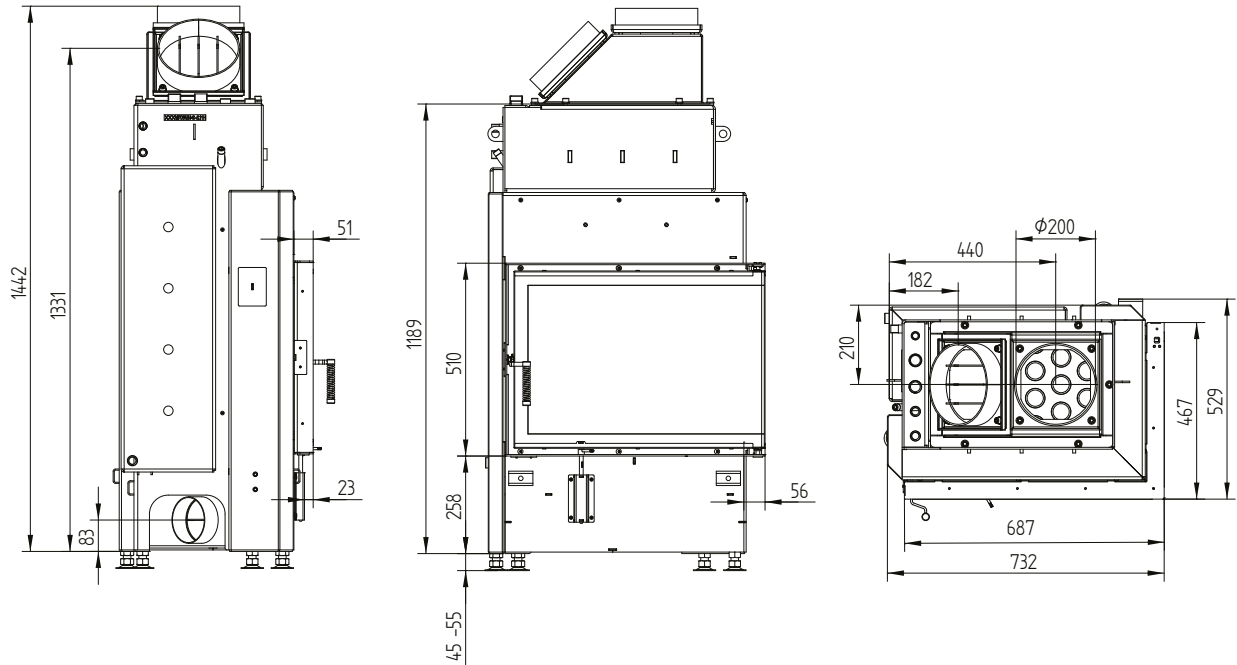

ECKA 67/45/51WR

Technical data
Version 09/2023

Cover frame 67/45/51 left-right side opening 6sides 1 x 90° 60 mm / air inlet

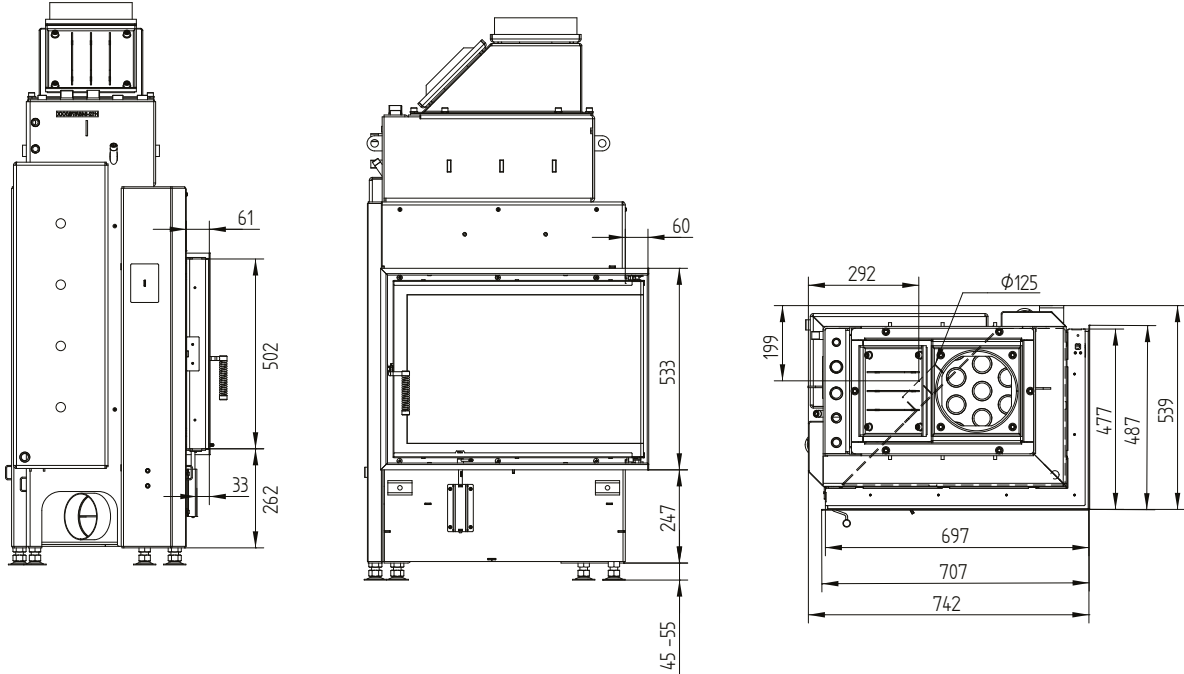

Build-on frame 67/45/51R right side opening 6sides 80 mm / feet

